



# SERVICE PARTS LIST

**BULLETIN NO.**  
**54-05-0030**

SPECIFY CATALOG NO. AND SERIAL NO. WHEN ORDERING PARTS			REVISED BULLETIN	DATE
<b>M18™/M28™ HammerVAC™ Dust Extractor</b>				June 2014
CATALOG NO.	<b>2715-DE</b>	SERIAL NUMBER	<b>G15A</b>	
				WIRING INSTRUCTION <b>See Page 2</b>

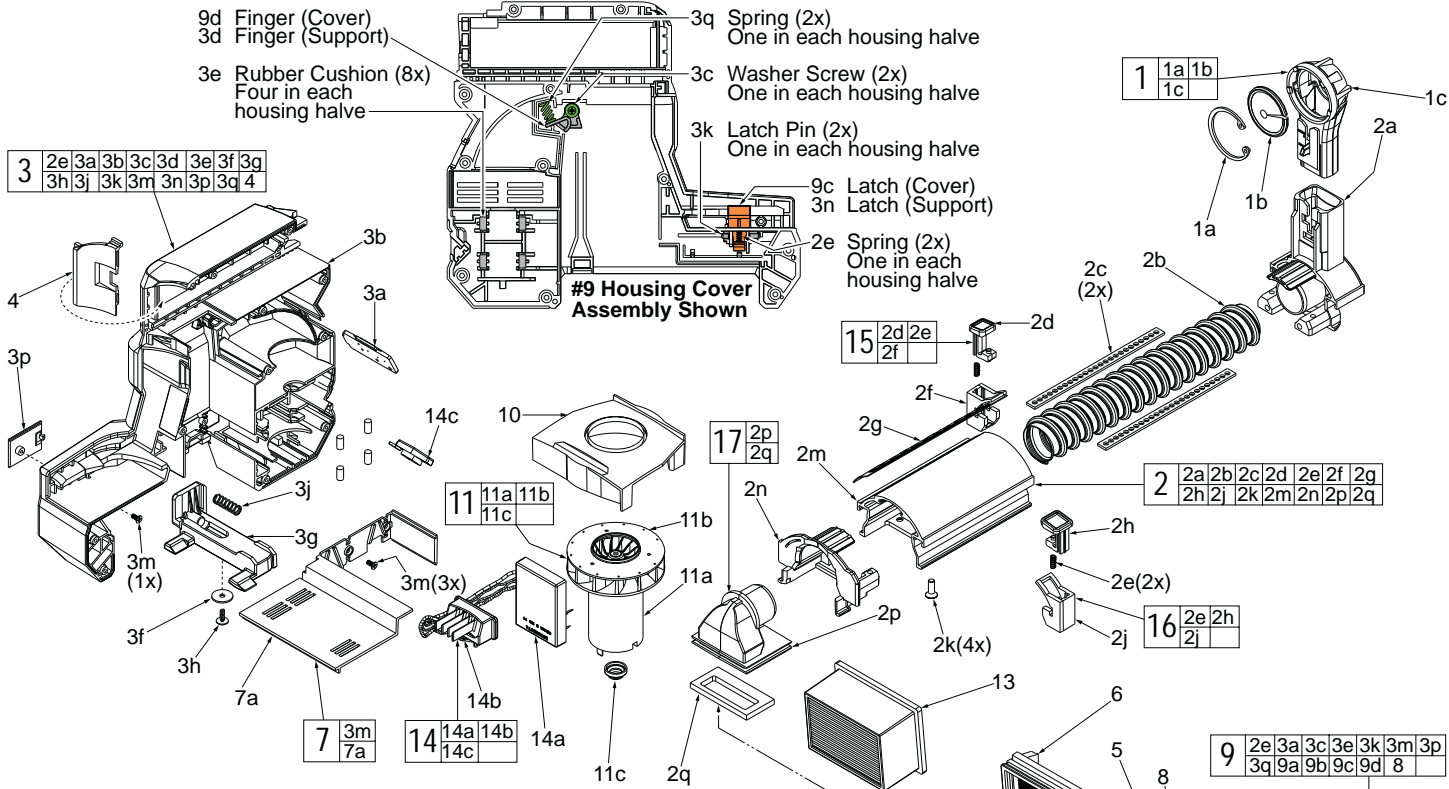

FIG.	PART NO.	DESCRIPTION OF PART	NO. REQ.
1	49-90-2301	Nozzle Top Assy. (Accessory, Pack of 2)	1
1a	-----	Retaining Ring	1
1b	-----	Hair Brush (Pack of 2)	1
1c	-----	Nozzle Top	1
2	45-76-2715	AL Tube Assembly	1
2a	31-12-0015	Nozzle Base	1
2b	45-76-0022	Spring Tube	1
2c	44-81-0040	Detent Plate	2
2d	-----	Depth Release Button	1
2e	-----	Spring	2
2f	-----	Depth Button Cover	1
2g	31-51-0155	Ruler	1
2h	-----	Zero Release Button	1
2j	-----	Zero Button Cover	1
2k	05-78-0135	Flat Hd. ST Phillips Screw	4
2m	-----	AL Tube	1
2n	31-12-1000	Rear Tube Cap	1
2p	-----	Dust Elbow	1
2q	43-44-0077	Gasket	1
3	14-38-2005	Housing Support Assembly	1
3a	43-84-2715	Housing Logo Insert	1
3b	-----	Housing Support	1
3c	-----	Screw	2
3d	-----	Finger - Support Side	1
3e	45-30-0003	Rubber Cushion	8
3f	45-88-2160	Washer	1
3g	44-20-0044	Button for Latch	1
3h	05-88-0030	M3 x 8.5mm Pan Hd. ST T-10 Screw	1
3j	40-50-0127	Latch Button Spring	1
3k	-----	Pin	2
3m	05-81-1100	M2.6 x 5mm Phillips Screw	5
3n	-----	Latch	1
3p	42-92-0012	Latch Cover	2
3q	-----	Spring	2
4	43-84-1010	Housing Insert - Support Side	1
5	42-38-0501	Rubber Bumper	1
6	45-60-0135	Finger Support Plate	1
7	31-15-2715	Wire Cover Plate Assembly	1
7a	-----	Wire Cover Plate	1
8	43-84-1015	Housing Insert - Cover Side	1
9	14-38-2010	Housing Cover Assembly	1
9a	-----	Housing Cover	1
9b	06-82-1080	M3.0 x 14mm Pan Hd. T-10 ST Screw	11
9c	-----	Latch	1

**EXAMPLE:**  
00 0 Component Parts (Small #)  
Are Included When Ordering  
The Assembly (Large #).

FIG.	PART NO.	DESCRIPTION OF PART	NO. REQ.
9d	-----	Finger - Cover Side	1
10	31-76-0105	Fan Shroud	1
11	14-50-2715	Motor/Fan Assembly	1
11a	-----	Motor	1
11b	-----	Fan	1
11c	43-44-1500	Rubber Cap Seal	1
12	49-90-2342	Dust Box (Accessory)	1
13	49-90-2306	Filter (Pack of 3)	1
14	14-20-2715	Electronics Assembly	1
14a	-----	PCBA	1
14b	-----	Terminal Block	1
14c	-----	LED	1
15	42-42-0285	Depth Release Button Assembly	1
16	42-42-0295	Zero Release Button Assembly	1
17	31-05-2000	Dust Elbow Assembly	1
18	12-20-0049	Service Nameplate (See Page Two)	1
19	10-20-0498	Tri-Lingual Warning Label (See Page Two)	1
20	10-20-4352	Dust Box Label (See Page Two)	1
21	10-20-0502	M18/M28 Label (See Page Two)	1

**MILWAUKEE TOOL • www.milwaukeetool.com**  
13135 W. LISBON RD., BROOKFIELD, WI 53005

# WIRING DIAGRAM

AS AN AID TO REASSEMBLY, TAKE NOTICE OF WIRE ROUTING AND POSITION IN WIRE GUIDES AND TRAPS WHILE DISMANTLING TOOL.

BE SURE THAT ALL COMPONENTS OF THE ELECTRONICS KIT ARE SEATED FIRMLY AND SQUARELY IN THE HOUSING RECESSES.

AVOID PINCHED WIRES, BE SURE THAT ALL WIRES AND SLEEVES ARE PRESSED COMPLETELY DOWN IN WIRE GUIDES AND TRAPS.

PRIOR TO INSTALLING THE HOUSING COVER ONTO THE HOUSING SUPPORT, BE SURE THAT THERE ARE NO INTERFERENCES.

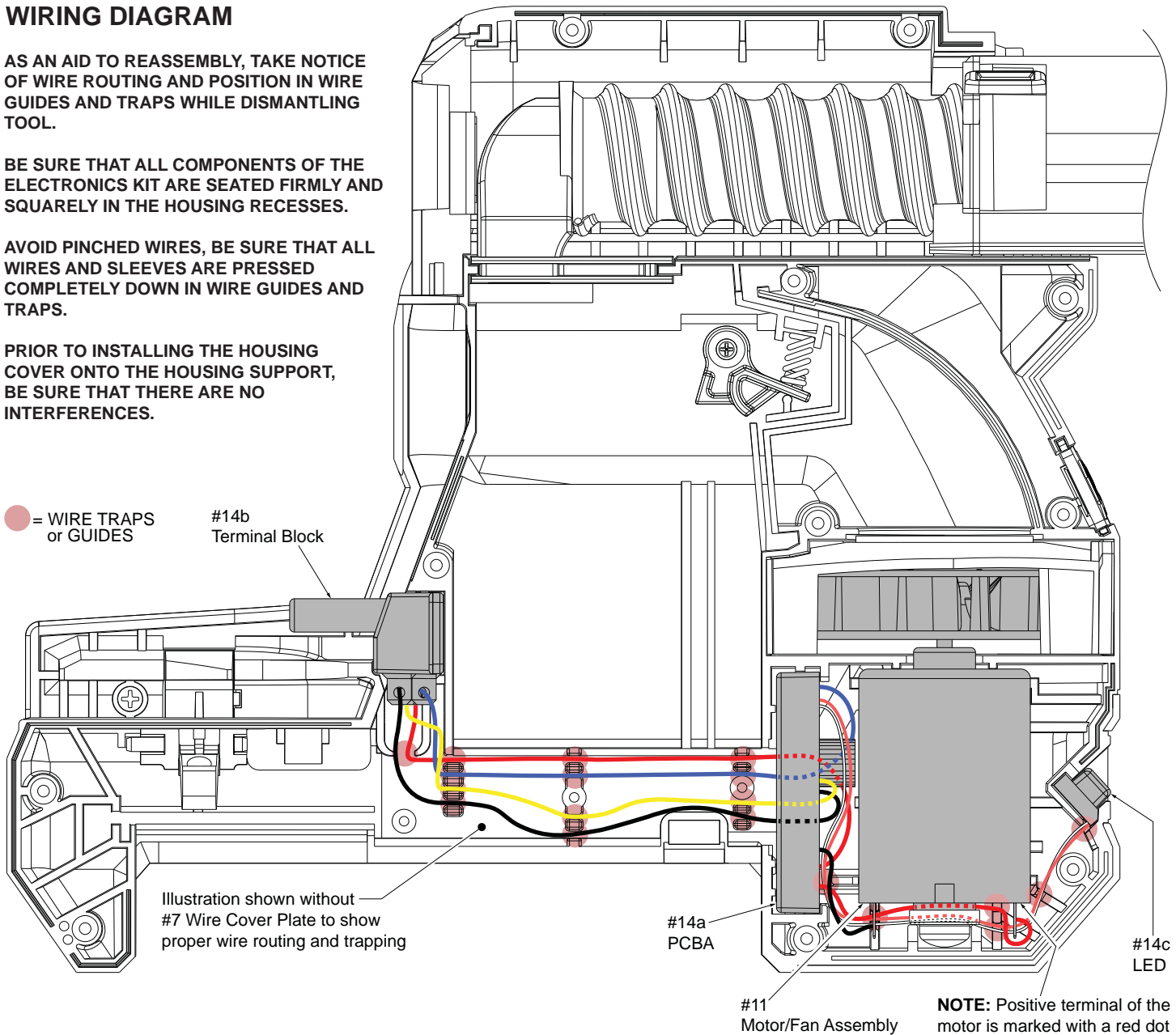

- 3m = 05-81-1100 Screw, Qty. 5
- 9b = 06-82-1080 Screw, Qty. 11

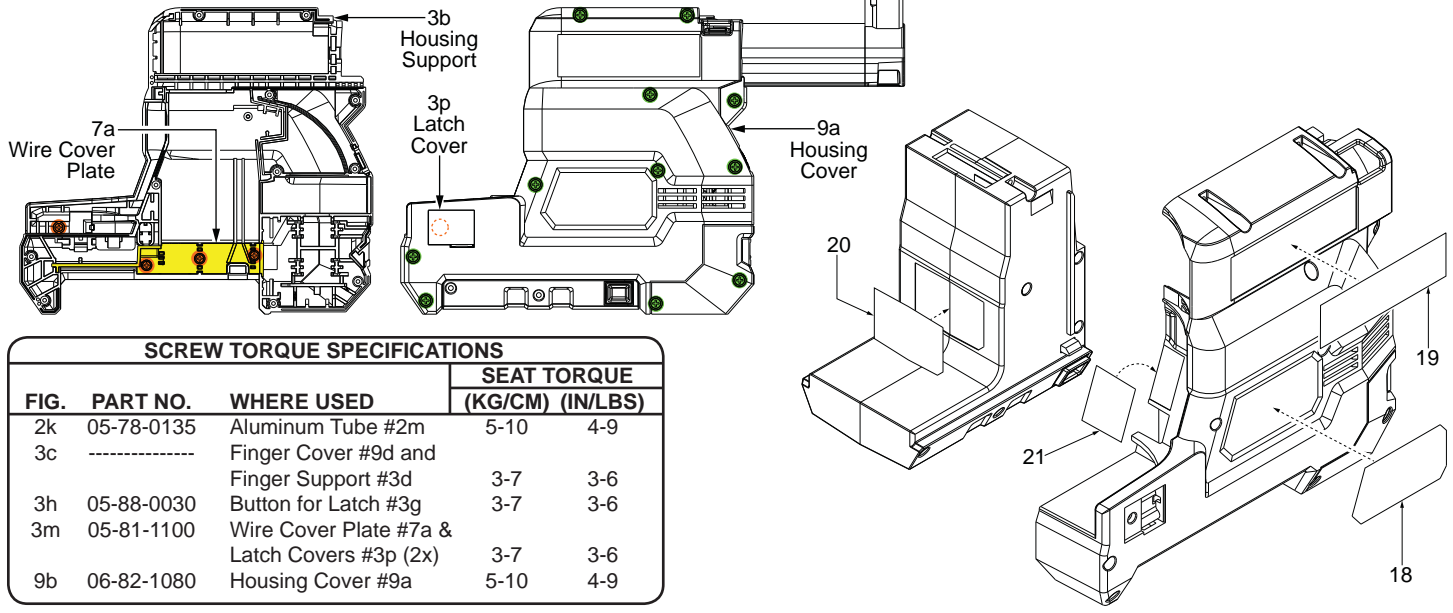

### SCREW TORQUE SPECIFICATIONS

FIG.	PART NO.	WHERE USED	SEAT TORQUE	
			(KG/CM)	(IN/LBS)
2k	05-78-0135	Aluminum Tube #2m	5-10	4-9
3c	-----	Finger Cover #9d and Finger Support #3d	3-7	3-6
3h	05-88-0030	Button for Latch #3g	3-7	3-6
3m	05-81-1100	Wire Cover Plate #7a & Latch Covers #3p (2x)	3-7	3-6
9b	06-82-1080	Housing Cover #9a	5-10	4-9